

Finger jointing lines CombiPact

High performance for horizontal and vertical joints

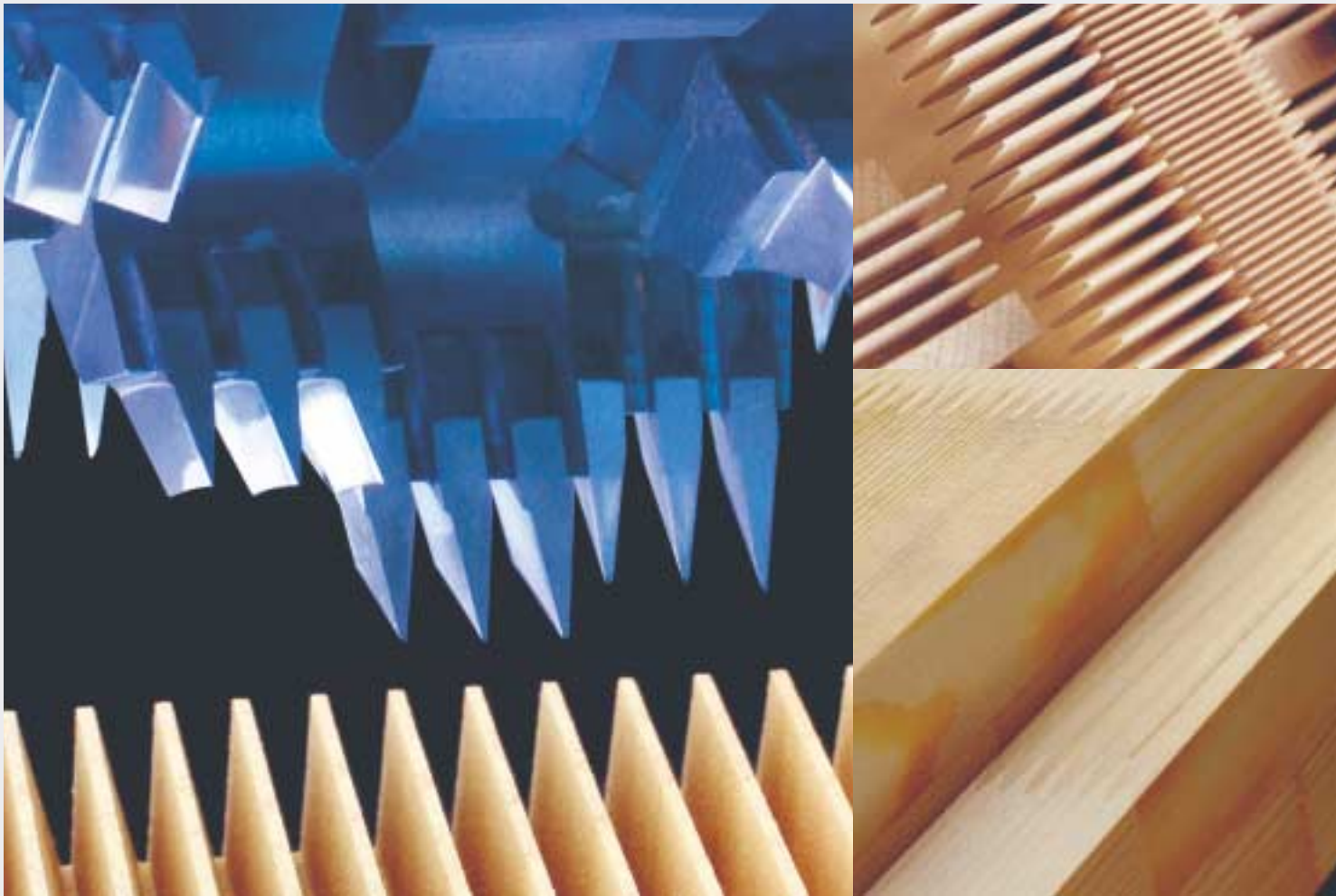

GRECON Finger jointing line CombiPact – State-of-the-art technology for tomorrows demand

GRECON is the leading manufacturer of innovative finger jointing lines. The finger jointing line type CombiPact is our response to the high quality demands in the timber industry. No matter whether vertical, horizontal or special profiles – with this universal machine you are able to handle all jobs – quickly and with high precision.





The CombiPact –

- Modern compact system with clearly arranged operations.
- The line especially features performance, high speed and jointing of top quality.
- High production capacities thanks to the full automatic passage through the line.
- Short feeding times due to preliminary alignment of the wood packages.
- No run of the shaper table without wood package.
- The solid basic body with the two opposite shaper units forms the heart of the system.

Grecon



WEINIG
GROUP

13:13:56

Order

24.04.2007

Timber width / thickness 65.00 / 23.00 mm

Target 1 : Quantity / Length 1 / 6340.00 mm

Target 2 : Quantity / Length 0 / 0.00 mm

Target 3 : Quantity / Length 0 / 0.00 mm

Quantity Pressing Cycles Target / Actual 0 / 0



Shaper

Press

Parameter

WZL_J
4x1.5m³

M1/U1

M1/V1

M1/W1

M1/PE

Finger jointing with GRECON: Highest quality standard in all capacity ranges

Perfected technology and innovative overall concepts characterize the package shapers. No matter what the field of application is – furniture and interior fitting, stairs, window scantlings, doors, profiles, etc. The GRECON finger jointing lines are taken as an industry standard with regard to precision and quality.

In addition, you can make a profit from the increasing popularity of finger jointed solid wood products sold in a variety of markets.

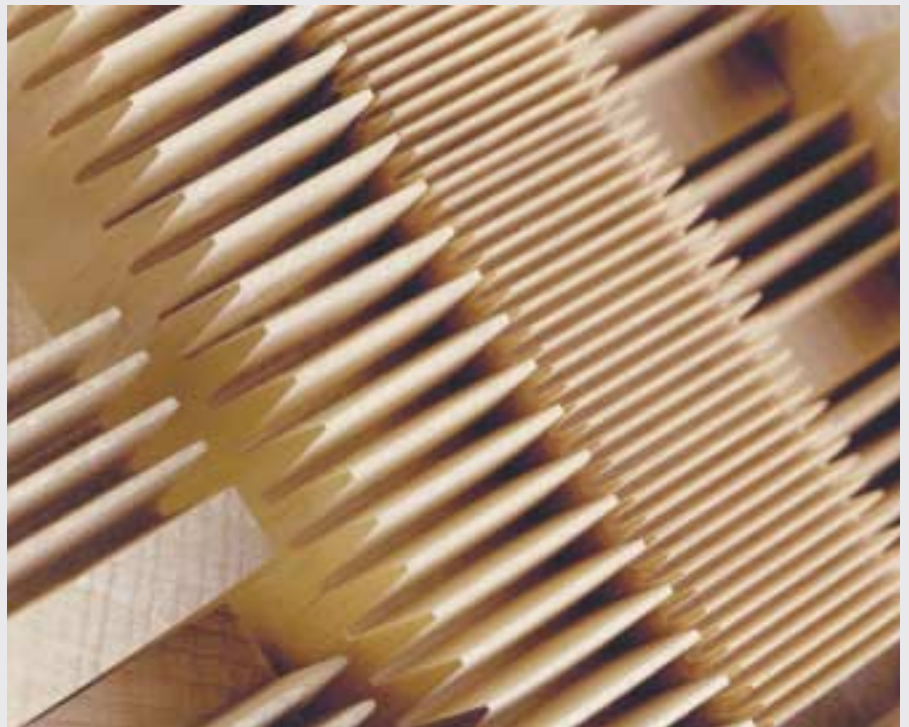

GRECON CombiPact – Simple and optimized feeding



Feeding by compartment-type conveyor

The feeding by a compartment-type conveyor is a comfortable alternative to the high speed feeding system of the CombiPact lines. A higher capacity of the line is guaranteed by a feeding from two sides (optionally). The "lifting-lowering function" of the first compartment makes an easy filling of the buffer (optionally) possible.



Feeding station

Due to the maintenance-free feeding station, the timber pieces are automatically aligned at their front end and fed into the shaping unit. The reverse motion of the transport belt ensures the alignment at the frequency-controlled pusher. At the same time when a completely processed timber package leaves the processing unit, the next package is precisely positioned in the clamping station.

GRECON CombiPact – Optimum processes incl. a high standard of tools



Complete automation through and through

Once the timber package has been fed into the feeding unit, the following processes are carried out fully automatically: Alignment, shaping, glueing, discharge, separation, joining and pressing. All line components match each other perfectly and ensure an efficient and troublefree operation at the highest rate of utilization possible.

Thanks to the exact dosage of the glue application »Flankenjet« developed by GRECON, a glue saving of up to 30 % is achieved.

An excellent tool configuration

including scoring saws from the top and bottom, hogs and cutters (adjustable within a 1/100 mm range) is the basis of the production of precise finger joint profiles. The scoring saws are synchronized to prevent tear out. The indirect drive of the maintenance-free WEINIG built tool spindles ensures high capacity reserves and vibration-free processing of short timber pieces. This ensures precise joint quality without any chip-out from the finger base to finger point and an absolutely tight finger joint.





The tool technology

is state of the art. Finger lengths from 4 up to 15 / 16,5 mm can be processed. Cutters having a diameter of 250 and 260 mm (at a finger length of 15 / 16,5 mm) and produced by various tool manufacturers process the requested finger profile up to 205 mm (cutting height) at a very high speed, with highest precision and quality.

GRECON CombiPact – Highest degree of safety, perfect finger joints

The top pressure beams of the clamping stations can be adjusted to the cutting height. Thus the reduction of the lift of stroke minimizes the clamping time and increases the productivity. The pressure control of the clamping stations ensures absolute production safety.

The swivelling splinter protection sits close to the timber package during the shaping process avoiding tear-outs at the finger joints of the very last timber piece. All this results in finger-jointed timber lengths which require the minimum of further processing.

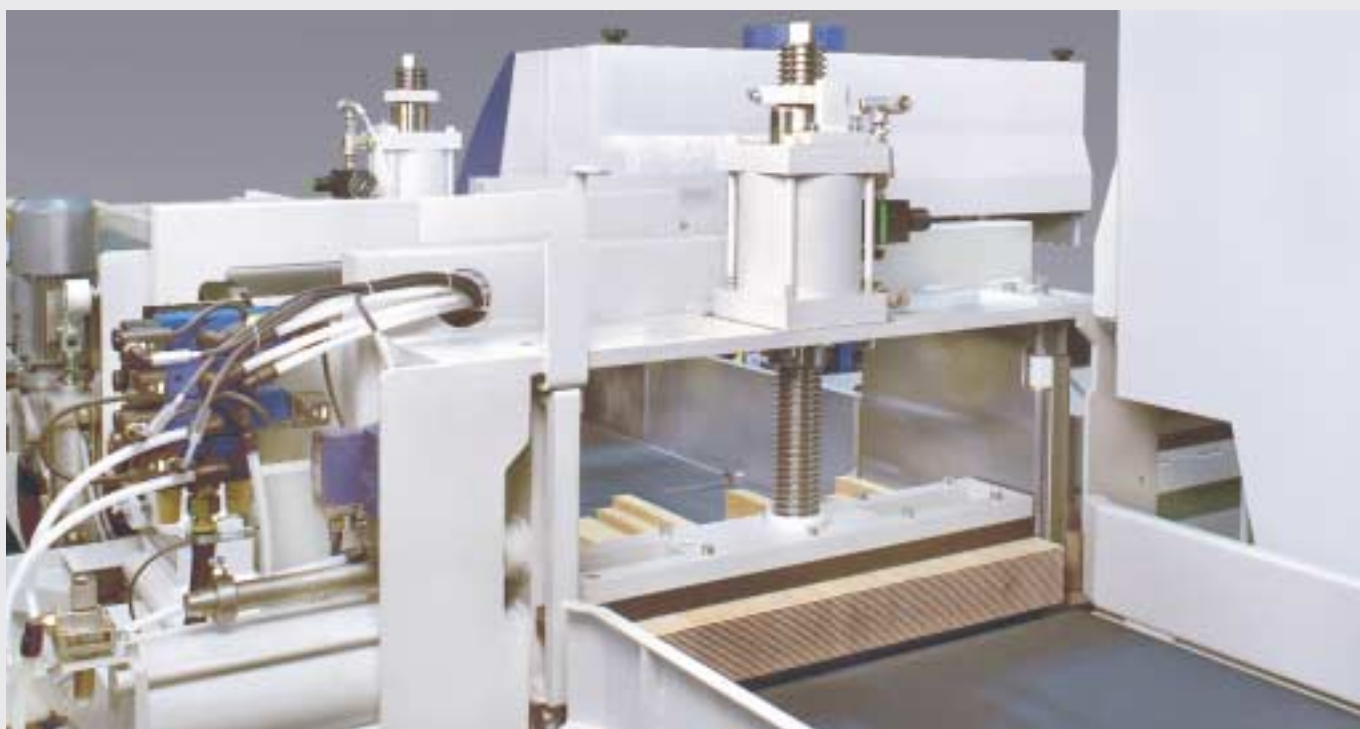

GRECON CombiPact – Perfection in detail

- Frequency-controlled transport belts at optimum speed and positioning at the limit stops (optional).
- Fully automatic transfer station incl. patented suction air belt to transfer the pieces to the feed-in track without any slipping.
- Maintenance-free servo cross transport device for the separation of the finger-jointed timber packages.
- The liftable and lowerable function of the transfer station ensures precise adjustment of the table in order to reliably separate the vertically finger-jointed timber packages. In case of horizontally finger-jointed packages, the transfer station is on the same level as the suction air belt.
- The speed of the frequency-controlled, brush-type motor can be adjusted as required to carry out the separation of the finger-jointed timber pieces. Each timber piece is quickly positioned on the suction air belt.
- Feed-in track including non-contact, electronic filling control.
- Lateral chains and pressure rollers (optional) ensure the precise alignment of the timber bar on one side.
- Automatic lubricating device (oil)



used for the chains.

- Frequency-controlled feed motors ensure fast feeding of the press.
- A brake unit required for and the subsequent length measurement ensure the exact feeding of the press.
- Two-channel-press; feeding and pressing are carried out at the same time; capacities up to 12 cycles per min. / 73 m per min., (240 ft / min.) (optional).
- Intermediate cuts are possible by entering the dimensions at the central operating panel.
- Even the shortest timber pieces are perfectly positioned in the press area by means of an additional cross pusher installed in the infeed area of the press.
- Automatic adjustment of the final length at the press (optional).



Finger jointing lines CombiPact: Standards and options

Only the intertwining of all automation modules by control technique on highest level makes permanent and continuous performances without interruptions possible. GRECON experts develop solutions for your specific requirements from proven, reliable elements.

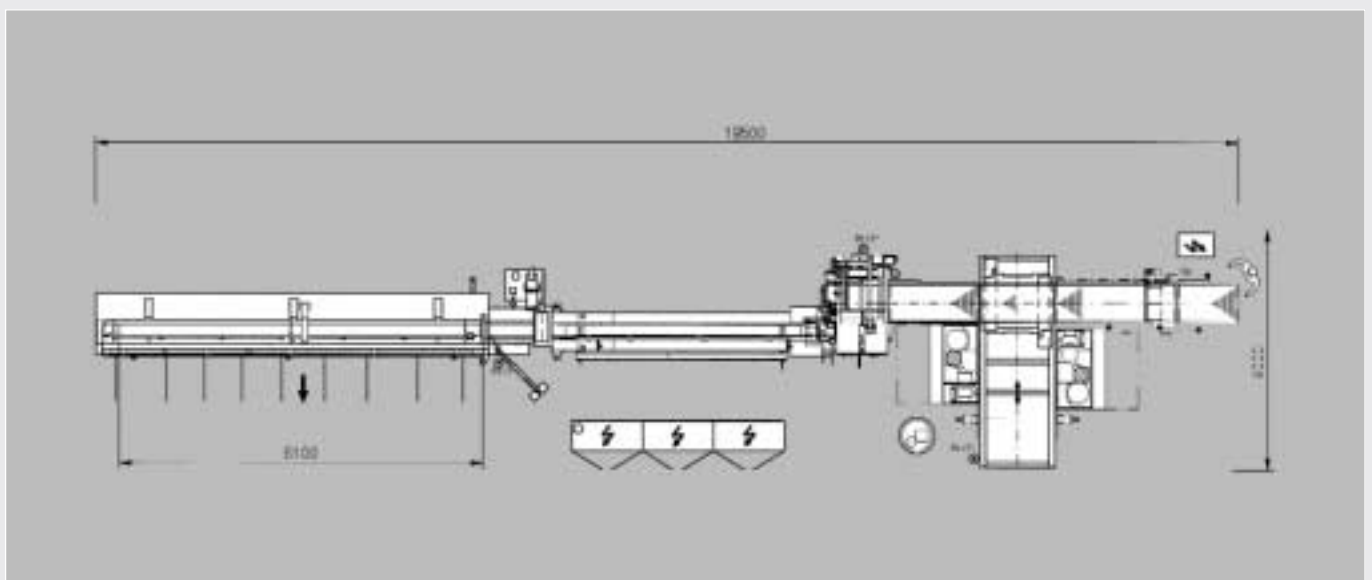
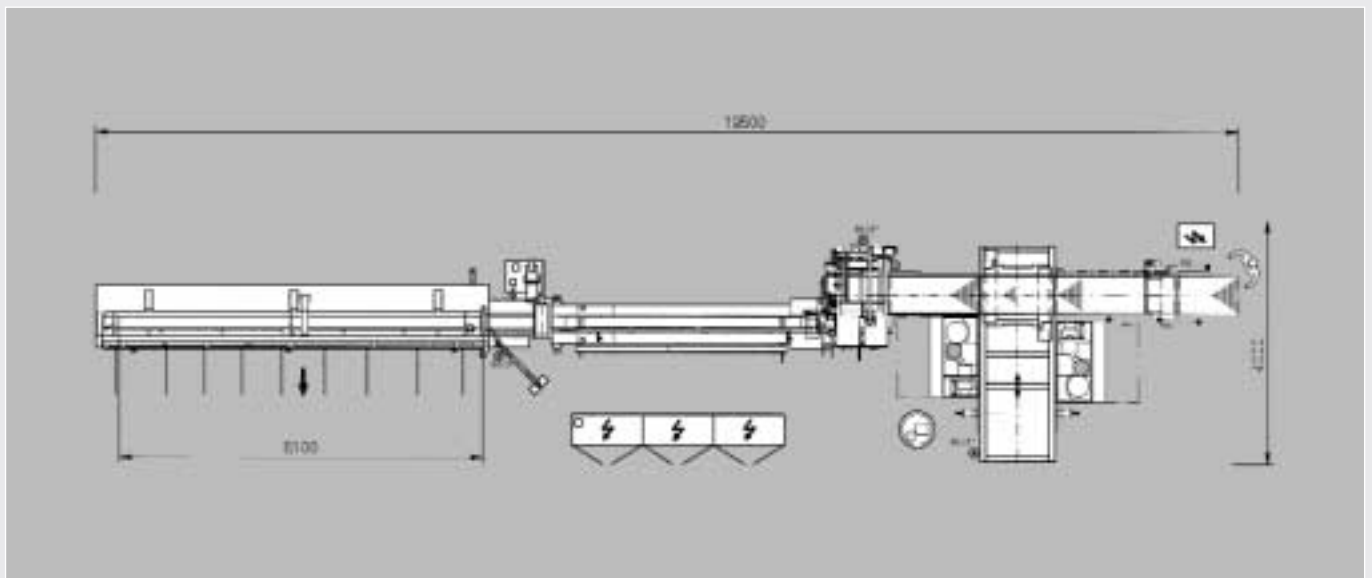



The matrix shows the significant features.
Your GRECON expert provides you any information
taking into consideration your individual needs.

Facts	CombiPact
Infeed length	150 - 1.000 mm
Timber width	40 - 205 mm
Timber thickness	20 - 80 mm
Outfeed length	3.000 - 6.100 mm
Thrust force	120 (145) kN
Timber cross section at a finger length of 10/11mm(softwood)	120 (145) cm ²
Timber cross section at a finger length of 10/11 mm (hardwood)	90 (110) cm ²
Capacity (vertical jointing) with 30x90x400	41,8 m/min
Capacity (horizontal jointing) with 22x50x350	19,25 m/min
Feeding system	Feeding conveyor/compartment type conveyor
Shaper types	Package shaper combination
Transfer	automatic, servo-controlled
Press	Two-channel press
Production statistics	●
Diagnosis system	●
Multiple lengths	●
Intermediate cuts	∞
Fächerbeschickung	○
Horizontalzinkung	○
Timber tear-out prevention (scoring unit at the bottom)	○
Timber thickness min. 16 mm	○
Timber thickness max. 72 mm	○
Timber thickness max. 100 mm	○
Vibratory stop	●
Timber monitoring	●
Splinter protection	●
Glue application system FlankenJet	●
Verschiedene Leimarten	○
Communication (teleservice)	○
Capacity reserve cutter spindle drive (37 kW)	○
Frequency controlled advance	●
Power shaper	22 (37)kW
Power hogger (+ scoring unit)	11,5 kW

We will meet all of your expectations: WEINIG GROUP – Your partner for the future

Concentrate on your business, we will do the rest for you!
The WEINIG GROUP is not only the leading technology supplier for the solid wood processing industry and trade. With comprehensive services and system solutions to turnkey production plants the WEINIG GROUP is your ideal all-around partner, whenever production has to be flexible and profitable.



The WEINIG ExpoCenter

In our ExpoCenter we demonstrate what top technology can do for your. Here, you can see our machines life in operation.



Training

We want that you benefit the best way possible as quickly as possible from your investment. The proven WEINIG training concepts provides for it. Effective training by experiences WEINIG experts ensures that the machine will be available to you with its full potential.



Kaizen

The production organisation at WEINIG is based on the Kaizen method, consequently and successfully. In a continuous improvement process quality and efficiency are optimised step-by-step. Benefit from it for your business: we appreciate to impart our experience of many years in workshops.



Service

With offices in all parts of the world and a large, mobile team of service technicians we guarantee worldwide service, which is unique in this industry. Quickest spare parts supplies at any place as well as contact partners who speak your language are part of our traditional customer orientation.



WEINIG

World market leader for moulding machines

WACO

No.1 for high-performance planers and moulding machines

GRECON

Powerful finger jointing lines

DIMTER

Specialist for optimising cut-off saws and gluing presses

RAIMANN

Advanced technique for cut-optimisation

CONCEPT

The competent partner for overall solutions

The WEINIG GROUP: We combine all components from the solid wood treatment seamlessly

To the turnkey production plant

To build innovative machines is one thing, to offer system solutions is something completely different. More and more often our customers wish to have the whole works. This is a job for our team of WEINIG CONCEPT where the competence of the WEINIG GROUP is combined in a very special way. From planning to turnkey production-

plants, our pros do the entire job. Worldwide. Taking the complete responsibility. For you.

A strong team

From planning to turnkey production plants, our pros do the entire job. Worldwide. Taking the complete responsibility. For you.



Finger jointing lines CombiPact



Production:

GRECON DIMTER Holzoptimierung
Nord GmbH & Co. KG
Hannoversche Straße 58
31061 Alfeld / Hannover
Germany

Phone +49 (0) 51 81 / 9 39-0
Fax +49 (0) 51 81 / 9 39-2 25
E-mail info@grecon-weinig.de
Internet www.weinig.com

Sales:

WEINIG GROUP
Weinigstraße 2/4
97941 Tauberbischofsheim
Germany

Phone +49 (0) 93 41 / 86-0
Fax +49 (0) 93 41 / 70 80
E-mail info@weinig.de
Internet www.weinig.com